

FloPlast Ltd

Castle Road
Eurolink Business Park
Sittingbourne
Kent ME10 3FP

Tel: 01795 431731 Fax: 01795 431188

e-mail: sales@floplast.co.uk

website: www.floplast.co.uk



Agreement Certificate

00/3772

Product Sheet 1

FLOPLAST WHITE PVC-UE CLADDING SYSTEMS

FLOPLAST PVC-UE CLADDING SYSTEM

This Agrément Certificate Product Sheet⁽¹⁾ relates to the FloPlast PVC-UE Cladding System, comprising white PVC-UE cladding planks, rigid PVC-U trims and ancillary items, fixed horizontally to timber battens, and used as a cladding system to provide a back-ventilated, decorative and protective facade over masonry and timber-frame wall constructions of new and existing buildings.

(1) Hereinafter referred to as 'Certificate'.

CERTIFICATION INCLUDES:

- factors relating to compliance with Building Regulations where applicable
- factors relating to additional non-regulatory information where applicable
- independently verified technical specification
- assessment criteria and technical investigations
- design considerations
- installation guidance
- regular surveillance of production
- formal three-yearly review.

KEY FACTORS ASSESSED

Strength and stability — the system can withstand dynamic wind pressures not exceeding 1750 Pa (see section 6).

Performance in relation to fire — the system achieved a reaction to fire classification of D-s3, d2/(AHM) to BS EN 13501-1 : 2007 (see section 7).

Air and water penetration — the design of the vertical and horizontal joints between the planks will minimise water entering the air cavity. Any water collecting in the cavity will be removed by drainage and ventilation (see section 8).

Durability — the system will remain effective as a cladding system for a period in excess of 35 years, with only minor changes in surface appearance (see section 11).



The BBA has awarded this Certificate to the company named above for the system described herein. This system has been assessed by the BBA as being fit for its intended use provided it is installed, used and maintained as set out in this Certificate.

On behalf of the British Board of Agrément

Date of Second issue: 23 May 2017

John Albon – Head of Approvals
Construction Products

Originally certificated on 19 March 2001

Claire Curtis-Thomas
Chief Executive

The BBA is a UKAS accredited certification body – Number 113.

*The schedule of the current scope of accreditation for product certification is available in pdf format via the UKAS link on the BBA website at www.bbacerts.co.uk
Readers are advised to check the validity and latest issue number of this Agrément Certificate by either referring to the BBA website or contacting the BBA direct.*

British Board of Agrément

Bucknalls Lane
Watford
Herts WD25 9BA

tel: 01923 665300

fax: 01923 665301

clientservices@bbacerts.co.uk

www.bbacerts.co.uk

©2017

Regulations

In the opinion of the BBA, the FloPlast PVC-UE Cladding System, if installed, used and maintained in accordance with this Certificate, can satisfy or contribute to satisfying the relevant requirements of the following Building Regulations (the presence of a UK map indicates that the subject is related to the Building Regulations in the region or regions of the UK depicted):



The Building Regulations 2010 (England and Wales) (as amended)

Requirement:	A1	Loading
Comment:		The system is acceptable for use as set out in section 6 of this Certificate.
Requirement:	B3(2)(4)	Internal fire spread (structure)
Requirement:	B4(1)	External fire spread
Comment:		The system achieved a reaction to fire classification of D-s3, d2/(AHM) and so its use is restricted under these Requirements. See sections 7.1 to 7.4 of this Certificate.
Requirement:	C2(b)(c)	Resistance to moisture
Comment:		The system does not form a watertight or airtight facing. To achieve a waterproof barrier on exposed substrates a breather membrane must be provided. See section 8 of this Certificate.
Regulation:	7	Materials and workmanship
Comment:		The system is acceptable. See section 11.1 and the <i>Installation</i> part of this Certificate.



The Building (Scotland) Regulations 2004 (as amended)

Regulation:	8(1)(2)	Durability, workmanship and fitness of materials
Comment:		The system is acceptable. See sections 10 and 11.1 and the <i>Installation</i> part of this Certificate.
Regulation:	9	Building standards applicable to construction
Standard:	1.1(a)(b)	Structure
Comment:		The system can contribute to satisfying this Standard, with reference to clause 1.1.1 ⁽¹⁾⁽²⁾ , as set out in section 6 of this Certificate.
Standard:	2.4	Cavities
Standard:	2.6	Spread to neighbouring buildings
Standard:	2.7	Spread on external walls
Comment:		The system is restricted by these Standards, with reference to clauses 2.4.2 ⁽¹⁾⁽²⁾ , 2.4.4 ⁽¹⁾ , 2.4.7 ⁽¹⁾ , 2.4.9 ⁽²⁾ , 2.6.2 ⁽¹⁾⁽²⁾ , 2.6.4 ⁽¹⁾⁽²⁾ and 2.7.1 ⁽¹⁾⁽²⁾ , as set out in sections 7.1 to 7.3 and 7.5 of this Certificate.
Standard:	3.10	Precipitation
Comment:		The system does not form a watertight or airtight facing. To achieve a weatherproof barrier on exposed substrates, a breather membrane must be provided. See section 8 of this Certificate.
Standard:	3.15	Condensation
Comment:		Provided there is provision for adequate drainage and ventilation behind the cladding, and a breather membrane is incorporated if required, the system can contribute to satisfying this Standard, with reference to clauses 3.15.4 ⁽¹⁾ and 3.15.5 ⁽¹⁾ . See section 8 of this Certificate.

Regulation: 7.1(a) **Statement of sustainability**
Comment: The system can contribute to satisfying the relevant requirements of Regulation 9, Standards 1 to 6, and therefore will contribute to a construction meeting a bronze level of sustainability as defined in this Standard.

Regulation: 12 **Building standards applicable to conversions**
Comment: All comments given for this system under Regulation 9, Standards 1 to 6, also apply to this Regulation, with reference to clause 0.12.1⁽¹⁾⁽²⁾ and Schedule 6⁽¹⁾⁽²⁾.

(1) Technical Handbook (Domestic)
(2) Technical Handbook (Non-Domestic).



The Building Regulations (Northern Ireland) 2012 (as amended)

Regulation: 23 **Fitness of materials and workmanship**
Comment: The system is acceptable. See section 11.1 and the *Installation* part of this Certificate.

Regulation: 28(b) **Resistance to moisture and weather**
Comment: The system does not form a watertight or airtight facing. To achieve a waterproof barrier, a breather membrane must be provided. See section 8 of this Certificate.

Regulation: 29 **Condensation**
Comment: Provided there is provision for adequate drainage and ventilation behind the cladding, and a breather membrane is incorporated if required, the system can contribute to satisfying this Regulation. See section 8 of this Certificate.

Regulation: 30 **Stability**
Comment: The system is acceptable for use as set out in section 6 of this Certificate.

Regulation: 35(2)(3) **Internal fire spread — Structure**
Regulation: 36(a) **External fire spread**
Comment: The system achieved a reaction to fire classification of D-s3, d2/(AHM) and so its use is restricted under these Regulations. See sections 7.1 to 7.4 of this Certificate.

Construction (Design and Management) Regulations 2015

Construction (Design and Management) Regulations (Northern Ireland) 2016

Information in this Certificate may assist the client, designer (including Principal Designer) and contractor (including Principal Contractor) to address their obligations under these Regulations.

See sections: 3 *Delivery and site handling* (3.3) and 13 *General* (13.4) of this Certificate.

Additional Information

NHBC Standards 2017

NHBC accepts the use of the FloPlast PVC-UE Cladding System provided it is installed, used and maintained in accordance with this Certificate, in relation to *NHBC Standards*, Part 6 *Superstructure (excluding roofs)*, Chapters 6.1 *External masonry walls* (section 6.1.16 — Cladding) and 6.2 *External timber framed walls*.

CE marking

The Certificate holder has taken the responsibility of CE marking the system in accordance with harmonised European Standard BS EN 13245-2 : 2008. An asterisk (*) appearing in this Certificate indicates that data shown are given in the manufacturer's Declaration of Performance.

Technical Specification

1 Description

1.1 The FloPlast PVC-UE Cladding System comprises protective and decorative white PVC-UE cladding planks with a shiplap joint and matching rigid PVC-U trims (see Figures 1 and 2).

Figure 1 FloPlast Shiplap PVC-UE Cladding

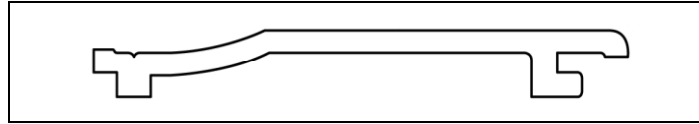
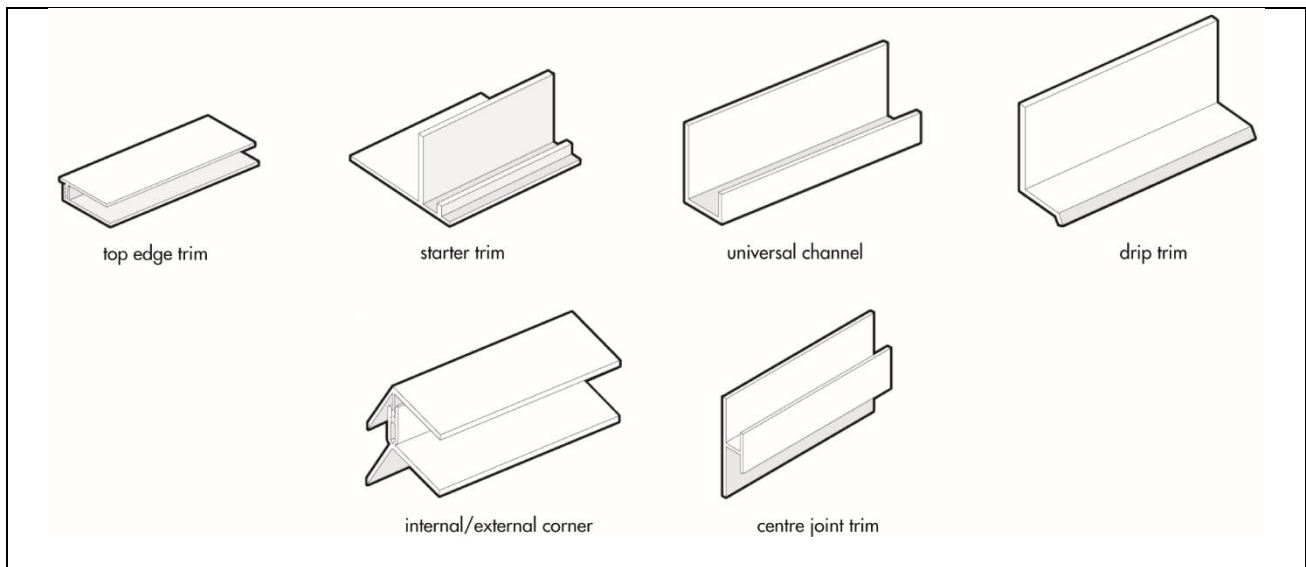

Figure 2 Extruded Trims



1.2 The interlocking planks are available in shiplap design, with the characteristics given in Table 1. The planks are composed of a closed cell cellular PVC-UE core beneath a rigid outer weathering impact-modified PVC-U skin.

1.3 The trims consist of extrusions of impact-modified PVC-U or injection mouldings of PVC-U.

1.4 The planks' characteristics are given in Table 1.

Table 1 Characteristics of planks

Characteristic (unit)	Nominal value
Standard length (m)	5
Cover width (mm)	150
Nominal thickness (mm)	7
Nominal thickness of rigid outer surface (mm)	0.6

1.5 Ancillary items specified for use with the system but outside the scope of this Certificate include:

- stainless steel (marine grade), flat-headed nails — A4 (steel Number 1.4401 to BS EN 10088-2 : 2014), used to secret fix cladding planks and extruded trims to timber battens. Sizes: 30 or 50 mm long
- breather membrane — for use with the system on non-weathertight substrates
- timber battens — measuring not less than 19 by 38 mm (25 by 38 mm recommended by the manufacturer) preservative-treated battens, to provide support for cladding.

2 Manufacture

2.1 The planks are manufactured by co-extruding a high-impact PVC-U compound onto a foam PVC-U compound, cooling and forming to section. Cellular PVC-U (PVC-UE) is formed during the process by evolution of gas from sodium bicarbonate. A clear, protective polyethylene film is applied to the outer face of the extrusion before the board is cut to length.

2.2 The trims are manufactured by conventional extrusion and injection-moulding techniques.

2.3 As part of the assessment and ongoing surveillance of product quality, the BBA has:

- agreed with the manufacturer the quality control procedures and product testing to be undertaken
- assessed and agreed the quality control operated over batches of incoming materials
- monitored the production process and verified that it is in accordance with the documented process
- evaluated the process for management of nonconformities
- checked that equipment has been properly tested and calibrated
- undertaken to carry out the above measures on a regular basis through a surveillance process, to verify that the specifications and quality control operated by the manufacturer are being maintained.

2.4 The management system of FloPlast Limited has been assessed and registered as meeting the requirements of BS EN ISO 9001 : 2008 (Certificate FM 501414) and BS EN ISO 14001 : 2004 (Certificate EMS 538445) by BSI.

3 Delivery and site handling

3.1 Standard 5 m lengths of the extrusions are delivered to site in protective polythene-sleeve wrapping. Pack quantities vary according to profile size.

3.2 All packaging bears the Certificate holder's product code and the BBA logo incorporating the number of this Certificate.

3.3 Unloading should be carried out by hand to avoid damage to the components and they should be stored flat, in their protective wrapping, on a clean, level surface. Stacks must not exceed one metre in height and should be restrained to prevent collapse. To avoid damage, it is recommended that additional protection be provided when the planks are stored in the open.

3.4 Care must be taken when loading the boards and trims to avoid contact with solvents or materials containing volatile organic components.

Assessment and Technical Investigations

The following is a summary of the assessment and technical investigations carried out on the FloPlast PVC-UE Cladding System.

Design Considerations

4 General

4.1 The FloPlast PVC-UE Cladding System is suitable for fixing horizontally as a back-ventilated, decorative and protective external facing over timber-frame or masonry wall constructions of new and existing buildings above ground level.

4.2 The system is restricted for use in buildings up to four storeys in height for timber-frame constructions and up to 18 m in masonry constructions.

4.3 The wall and the sub-frame to which the cladding is fixed should be structurally sound and constructed in accordance with the requirements of the relevant national Building Regulations and Standards.

4.4 Brickwork or blockwork walls should be constructed in the conventional manner, in accordance with the national Building Regulations and BS EN 1996-1-1 : 2005 and BS EN 1996-3 : 2006 and their UK National Annexes.

4.5 Timber stud walls should be designed and constructed in accordance with the UK National Annex to BS EN 1995-1-1 : 2004. Studding and framing should be adequately supported by noggings to ensure rigidity.

4.6 When used over a sheathed timber stud frame or a masonry substrate, the cladding should be fixed to preservative-treated, good-quality timber battens (see section 1.5 of this Certificate) rigidly fixed to the studding (not unsupported sheathing) or masonry substrate at 600 mm centres or closer. Where a CCB (copper/chrome/boron) preservative is used, care should be taken to ensure that sufficient time is allowed for the complete fixation of the preservative (approximately seven days) before the cladding is fixed.

4.7 PVC-UE has a similar coefficient of thermal expansion to that of conventional rigid PVC-U. To avoid distortion in service, care should be taken not to install the cladding in extremes of temperature (ie below 5°C or above 25°C) and to allow adequate gaps for expansion (see the relevant sections of the *Installation* part of this Certificate.)

4.8 To comply with the NHBC requirement (see NHBC Standards 2017, Chapter 6.9.18), a minimum 38 mm drained and vented cavity behind the cladding is required.

4.9 Ventilation slots of a minimum 5000 mm² per metre run at the top and bottom of the installation is recommended.

5 Practicability of installation

The system is designed to be installed by a competent general builder, or a contractor, experienced with this type of system.

6 Strength and stability

Wind loading



6.1 Under wind loading, the most likely mode of failure of the cladding will be by nail withdrawal under wind suction. Wind loads should be calculated in accordance with BS EN 1991-1-4 : 2005 and its UK National Annex.

6.2 When installed in accordance with the requirements of this Certificate onto battens at 600 mm spacings, the cladding can withstand dynamic wind pressures up to 1750 Pa.

6.3 The permissible dynamic wind pressure may be increased by reducing batten spacing. This is particularly recommended at the corners of buildings and in exposed locations. In common with all cladding, the adequacy of a proposed installation should always be checked by a suitably qualified and experienced individual, who should include in the check the adequacy of the fixing of battens to the substrate, which is not covered by this Certificate.

6.4 The cladding should not be taken into account when designing a timber stud wall to resist racking forces.

Impact resistance



6.5 The cladding is not recommended for use at ground-floor level where severe impacts may occur. It is suitable for use above ground-floor level in locations where it is unlikely to be subjected to impact from thrown or kicked objects, and at ground-floor level in private areas where there is some incentive to exercise care.

7 Performance in relation to fire



7.1 The system achieved a reaction to fire classification* of D-s3, d2/(AHM) to BS EN 13501-1 : 2007. It may therefore not be used within 1 m of the relevant boundary and may be further restricted by requirements for unprotected areas.

7.2 Although the spread-of-flame across the surface of PVC is limited, the material does tend to char and may fall away when exposed to fire. Due consideration should always be given to any combustible materials behind the cladding, which may become exposed in the event of fire. Where necessary, cavity barriers should be incorporated behind the cladding, as required under the relevant national Building Regulations.

7.3 The limits for extent of unprotected area of a wall should be calculated in accordance with the methods given in the national Building Regulations.



7.4 When determining the minimum distance between the sides of a building and the relevant boundary, any area of wall (with appropriate fire resistance) covered by the system is counted as an unprotected area amounting to half the actual area of the cladding.



7.5 The system need not be included in the calculation of an unprotected area where:

- it is attached to the structure of the building and the external wall contains no openings other than the small openings described in clause 2.6.2b⁽¹⁾⁽²⁾ and
- the wall behind the system has the appropriate fire-resistance duration from the inside.

Otherwise, if these requirements are not met, the system must be treated as an unprotected area amounting to 100% opening.

(1) Technical Handbook (Domestic).

(2) Technical Handbook (Non-Domestic).

8 Air and water penetration



8.1 The cladding is not airtight, watertight or water-vapour tight. When used on exposed substrates, such as timber stud walls, the system must be backed by a breather membrane acting as a vapour-permeable water barrier, incorporated behind the cladding under the supporting battens. This barrier must meet the requirements of BS 5250 : 2011 and have a vapour resistance of less than $0.6 \text{ MN}\cdot\text{s}\cdot\text{g}^{-1}$.

8.2 Where cladding is used as a decorative facing attached to weathertight masonry walls, a vapour-permeable water barrier is not necessary as the amount of water that will penetrate the cladding will be small and will not have an adverse effect on the wall.

8.3 If the cladding is used in the renovation of a masonry wall which is structurally sound but not fully weathertight, the use of a vapour-permeable water barrier is advisable.

8.4 Provision must always be made to allow water that has penetrated behind the cladding to drain away.

9 Thermal insulation

For the purpose of U value calculations, in accordance with BS EN ISO 6946 : 2007 and BRE Report BR 443 : 2006, the cavity between the system and the wall should be treated as a 'well ventilated' air layer, and the thermal insulating value of the cavity — and everything between it and the external environment — should be taken as equivalent to an internal boundary layer (ie a total of $0.13 \text{ m}^2\cdot\text{K}\cdot\text{W}^{-1}$).

10 Maintenance



10.1 The cladding can be washed with water and detergent. Solvent-based cleaners should not be used.

10.2 Replacement of a damaged section can be carried out but may require the temporary removal of undamaged planks above the damaged area.

10.3 Paint should not be applied as it can cause premature embrittlement of PVC-U products and the application of dark colours to PVC-U cladding could lead to a risk of thermal distortion.

11 Durability



11.1 The system will remain effective as a cladding system for a period in excess of 35 years.

11.2 The cladding will retain its decorative function with only minor changes in surface appearance. However, staining will result from contact with certain materials or substances (eg creosote or bitumen).

12 Reuse and recyclability

The PVC-U profile material can be recycled.

Installation

13 General

13.1 The substrate for the system should be checked to ensure that it is as prescribed in section 4.2 of this Certificate. Installation must be carried out in accordance with the Certificate holder's instructions and the requirements of this Certificate.

13.2 Installation should not be carried out in extremes of temperature. For installation, a temperature range of between 5°C and 25°C is recommended by the Certificate holder.

13.3 The components can be worked using normal woodworking tools for cutting, drilling and shaping. Handsaws should have a fine-toothed blade. Hand-held and bench-mounted power tools with a carbide-tipped blade should be run at speeds similar to, or higher than, those normally used for timber.

13.4 Where necessary, trims and planks are cut to size and shape with a fine-toothed saw. When using power tools to cut or shape the components, eye protection and a coarse-particle dust mask should be used.

13.5 Expansion gaps of 5 mm should be provided at the ends of each 5 m plank.

13.6 Adequate provision should be made for ventilation and drainage behind the cladding (see sections 4.8, 4.9 and 8.4 of this Certificate).

13.7 Where butt joints are made between planks, the ends of both planks should be fixed to battens.

13.8 Flat-headed, stainless steel (marine grade) A4 cladding pins (30 or 50 mm long) are used to fix cladding planks to timber battens (secret fixing); fixing trims are required.

14 Procedure

Preparation

14.1 Before installation commences, the cladding operation should be thoroughly planned and prepared.

14.2 A final inspection of the substrate should be made to confirm that it is as prescribed in section 4.3 of this Certificate.

14.3 Appropriate cladding planks and trims should be selected and assembled (see Figures 1, 2 and 3).

14.4 The appropriate battens (selected and treated in accordance with section 4.6 of this Certificate) should be fixed at centres not exceeding 600 mm. Additional batten sections are required at jointing positions.

14.5 Vertical battens are required at the ends of each section, at the sides of windows and at joints between planks. Horizontal battens should not be used at the top/bottom of either the installation or window/door openings, where

they may restrict ventilation and drainage. Similarly, it is recommended that the use of horizontal trims at the base of the cladding must not reduce the ventilation opening below 5000 mm² (see sections 4.8 and 4.9 of this Certificate).

14.6 On non-weatherproof substrates (eg timber-frame walls), a vapour-permeable water barrier must be installed behind battens.

14.7 Window heads and other protrusions should be protected by a suitable weatherproof membrane or flashing.

14.8 Working from the base to a level line, a starter trim is fixed to the timber studs or battens. Care should be taken to ensure that the starter trim does not obstruct the opening required for drainage and ventilation at the base of the cladding.

14.9 All vertical trims, followed by top trims, are then fixed to perimeter battens (including battens around windows).

14.10 Where two-part trims are required, only the back half is fixed at this stage.

14.11 The bottom cladding plank is located firmly in the starter trim and vertical trims, and fixed into place using the specified stainless steel nails, starting at one end or working from the centre outwards, nailing into each batten in turn. At the end of each plank, a 5 mm gap should be allowed for expansion (ie 10 mm between two board ends).

14.12 Subsequent planks are fitted into the preceding planks, ensuring that the shiplap joint is firmly closed, and nail heads are concealed by the overlap.

14.13 If necessary, the top plank is cut to fit the remaining space. Where this occurs, packing pieces taken from cladding offcuts should be placed behind the cut plank at each fixing centre.

14.14 Where sections longer than 5 m are to be clad, butt joints of adjacent cladding planks should be concealed by either a centre joint trim fixed to a batten or a butt joint trim fitted to the planks above and below the joint. A 10 mm expansion gap should be allowed between the planks, both ends of which should be securely fixed to battens. Where butt joint trims are used, the joints should be staggered, with a continuous plank above and below the joint. The positioning of these trims should be taken into account during the planning stage.

14.15 Where two-part trims have been used, the installation is completed by fastening the front part of the trim.

Figure 3 Typical installation details

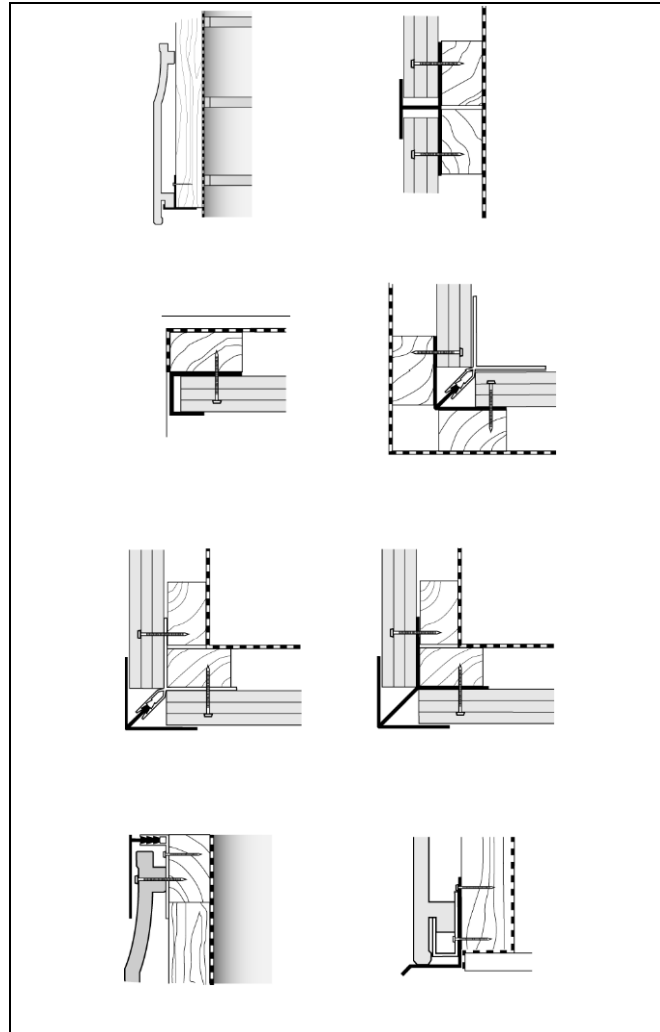

Technical Investigations

15 Tests

Tests were carried out to determine:

- Vicat softening point
- weight per linear metre
- ash content
- impact resistance
- impact resistance at -10°C
- voidage
- density
- flexural strength
- dimensional stability
- resistance to splitting and delamination (acetone)
- nail pull-through
- natural weathering
- accelerated weathering
- colour stability
- stress relief (heating)
- water absorption

- surface spread of flame
- fire propagation
- resistance to wind action.

16 Investigations

16.1 The manufacturing process was examined, including the methods adopted for quality control, and details were obtained of the quality and composition of materials used.

16.2 The practicability of installation was assessed.

16.3 An assessment was made of the ease of cleaning and of damaged profile replacement.

Bibliography

BS 5250 : 2011 + A1 : 2016 *Code of practice for control of condensation in buildings*

BS EN 1991-1-4 : 2005 + A1 : 2010 Eurocode 1 : *Actions on structures — General actions — Wind actions*

NA to BS EN 1991-1-4 : 2005 + A1 : 2010 UK National Annex to Eurocode 1 : *Actions on structures — General actions — Wind actions*

NA to BS EN 1995-1-1 : 2004 + A1 : 2008 UK National Annex to Eurocode 5 : *Design of timber structures — General — Common rules and rules for buildings*

BS EN 1996-1-1 : 2005 + A1 : 2012 Eurocode 6 : *Design of masonry structures — General rules for reinforced and unreinforced masonry structures*

NA to BS EN 1996-1-1 : 2005 + A1 : 2012 UK National Annex to Eurocode 6 : *Design of masonry structures — General rules for reinforced and unreinforced masonry structures*

BS EN 1996-3 : 2006 Eurocode 6 : *Design of masonry structures — Simplified calculation methods for unreinforced masonry structures*

NA + A1 : 2012 to BS EN 1996-3 : 2006 UK National Annex to Eurocode 6 : *Design of masonry structures — Simplified calculation methods for unreinforced masonry structures*

BS EN 10088-2 : 2014 *Stainless steels — Technical delivery conditions for sheet/plate and strip of corrosion resisting steels for general purposes*

BS EN 13245-2 : 2008 *Plastics — Unplasticized poly (vinyl chloride) (PVC-U) profiles for building applications — PVC-U profiles and PVC-UE profiles for internal and external wall and ceiling finishes*

BS EN 13501-1 : 2007 *Fire classification of construction products and building elements — Classification using data from reaction to fire tests*

BS EN ISO 6946 : 2007 *Building components and building elements — Thermal resistance and thermal transmittance — Calculation method*

BS EN ISO 9001 : 2008 *Quality management systems — Requirements*

BS EN ISO 14001 : 2004 *Environmental management systems — Requirements with guidance for use*

BRE Report (BR 443 : 2006) *Conventions for U-value calculations*

17 Conditions

17.1 This Certificate:

- relates only to the product/system that is named and described on the front page
- is issued only to the company, firm, organisation or person named on the front page – no other company, firm, organisation or person may hold claim that this Certificate has been issued to them
- is valid only within the UK
- has to be read, considered and used as a whole document – it may be misleading and will be incomplete to be selective
- is copyright of the BBA
- is subject to English Law.

17.2 Publications, documents, specifications, legislation, regulations, standards and the like referenced in this Certificate are those that were current and/or deemed relevant by the BBA at the date of issue or reissue of this Certificate.

17.3 This Certificate will remain valid for an unlimited period provided that the product/system and its manufacture and/or fabrication, including all related and relevant parts and processes thereof:

- are maintained at or above the levels which have been assessed and found to be satisfactory by the BBA
- continue to be checked as and when deemed appropriate by the BBA under arrangements that it will determine
- are reviewed by the BBA as and when it considers appropriate.

17.4 The BBA has used due skill, care and diligence in preparing this Certificate, but no warranty is provided.

17.5 In issuing this Certificate the BBA is not responsible and is excluded from any liability to any company, firm, organisation or person, for any matters arising directly or indirectly from:

- the presence or absence of any patent, intellectual property or similar rights subsisting in the product/system or any other product/system
- the right of the Certificate holder to manufacture, supply, install, maintain or market the product/system
- actual installations of the product/system, including their nature, design, methods, performance, workmanship and maintenance
- any works and constructions in which the product/system is installed, including their nature, design, methods, performance, workmanship and maintenance
- any loss or damage, including personal injury, howsoever caused by the product/system, including its manufacture, supply, installation, use, maintenance and removal
- any claims by the manufacturer relating to CE marking.

17.6 Any information relating to the manufacture, supply, installation, use, maintenance and removal of this product/system which is contained or referred to in this Certificate is the minimum required to be met when the product/system is manufactured, supplied, installed, used, maintained and removed. It does not purport in any way to restate the requirements of the Health and Safety at Work etc. Act 1974, or of any other statutory, common law or other duty which may exist at the date of issue or reissue of this Certificate; nor is conformity with such information to be taken as satisfying the requirements of the 1974 Act or of any statutory, common law or other duty of care.